

## Folding handles with recessed tray

### SPECIFICATION

#### Types

- Type **A**: with handle locking in the folded up or folded down position
- Type **B**: with spring return of the handle in the folded down position

#### Tray

Zinc die casting  
plastic coated  
black, RAL 9005, textured finish **SW**  
silver, RAL 9006, textured finish **SR**

#### Folding handle

#### Version in Steel

chrome plated **CR**

#### Version in Stainless Steel AISI 303

matt shot-blasted **NI**



### INFORMATION

The folding handles with recessed tray GN 425.8 are used if the handle is to protrude by a maximum of 3 mm when folded down.  
In type A, the folding handle is held in both end positions by spring-loaded thrust pieces.

In type B, the folding handle always spring-returns to the starting position after being released, preventing it from protruding with potentially interfering effect.

### TECHNICAL INFORMATION

- Stainless Steel characteristics (see page A26)
- Load rating information (see page A35)

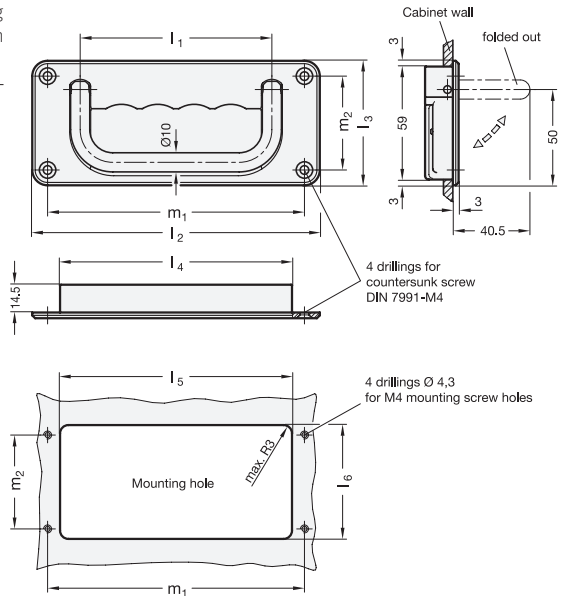

\* Complete with types of the Folding handles (A or B)

- A** with handle locking
- B** with spring return

### GN 425.8-CR

Description	l1	l2	l3	l4	l5	l6	m1	m2	⚖
GN 425.8-100-CR-SW-*	100	150	65	121	122	60	134	49	339
GN 425.8-100-CR-SR-*	100	150	65	121	122	60	134	49	339
GN 425.8-120-CR-SW-*	120	170	65	141	142	60	154	49	376
GN 425.8-120-CR-SR-*	120	170	65	141	142	60	154	49	376

### GN 425.8-NI

**STAINLESS STEEL**

Description	l1	l2	l3	l4	l5	l6	m1	m2	⚖
GN 425.8-100-NI-SW-*	100	150	65	121	122	60	134	49	339
GN 425.8-100-NI-SR-*	100	150	65	121	122	60	134	49	339
GN 425.8-120-NI-SW-*	120	170	65	141	142	60	154	49	376
GN 425.8-120-NI-SR-*	120	170	65	141	142	60	154	49	376

Weight type A